

Lubrication instructions for the Phoenix 1212

Lubricating the Z-Axis Assembly

A light amount of oil (3-in-1 preferred) should be used to coat the V-rails. Do not allow any excess oil to accumulate on the rails since it will attract dust and engraving chips. After applying lubricant, run the mechanism up and down the rail to evenly distribute the oil.

Lubricating the X-Axis Bridge Assembly

Same as above.

Lubricating the Y-Axis Linear Rails

Apply 2-3 drops of light oil on the rail and rub in with your fingers. XY jog the bridge back and forth to evenly distribute the oil.

Lubricating the X,Y,Z-Axis Lead Screws

A light lubrication of the X and Y lead screws should be performed after every week of usage. Use silicone lubricant only. To reach the Z-Axis lead screw, turn the spindle up/down knob to the furthest down position, which exposes the portion of the Z lead screw that requires lubrication. Spray a light coating along the lead screw.

HINT: To avoid having to remove the metal covers, use a nozzle extension for your can of spray lubricant. DO NOT use any lubricant other than silicone, as it may become sticky and cause a buildup that can cause mechanical failure.

What NOT to Lubricate

Many of the bearings and assemblies in your engraving machine are sealed and/or coated using special low-friction methods and should not be lubricated.

Do not attempt to lubricate the spindle or the spindle bearings. If you suspect lubrication problems, call your dealer/representative for instructions, as further lubrication may harm the machine.

Do not oil the X or Y stepper motors. The only motor that requires lubrication is the Z-motor and lead screw combination. (See lubricating the Z-axis assembly above.) Oiling the stepper motors can permanently damage the motors.

(Figure 2.1) The Phoenix 1212 (non-moving T-slot table)

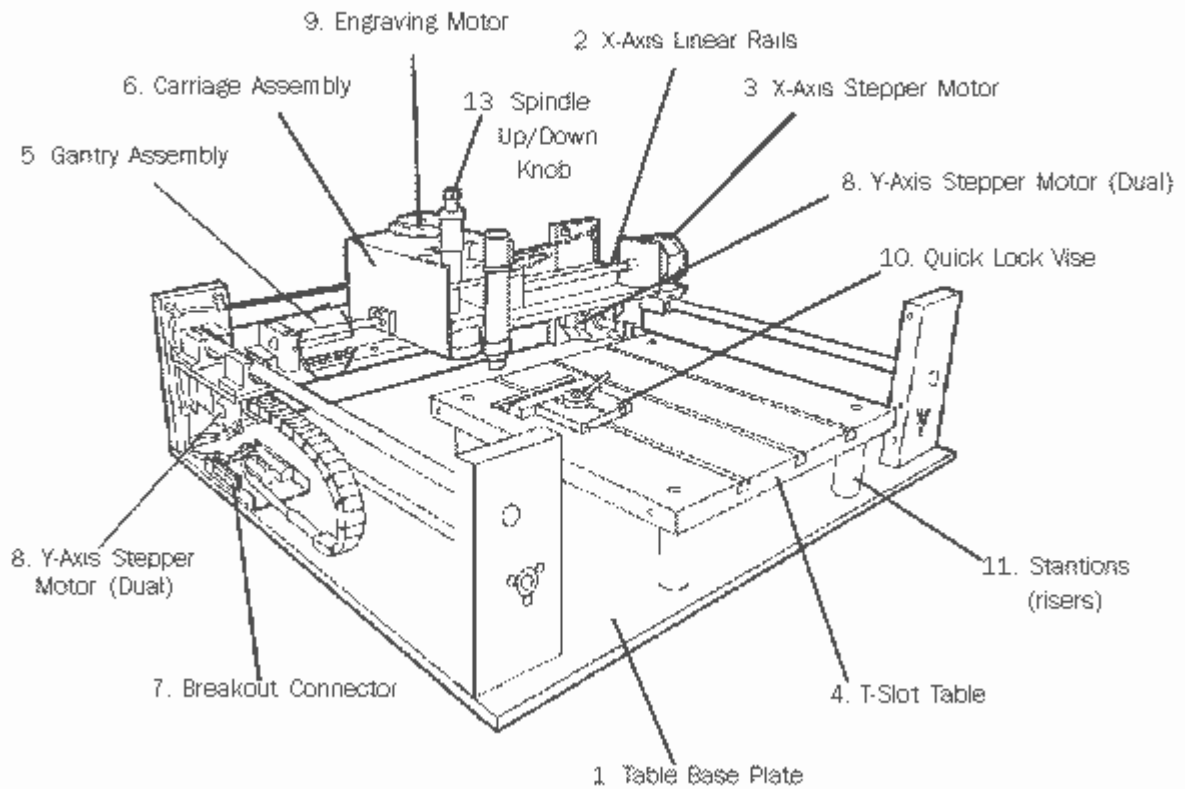

(Figure 2.2) Current Phoenix Carriage Front view with metal covers removed

